



# VAPOR TIGHT VENT

MODEL POTA PRESSURE ONLY TO ATMOSPHERE



## PRESSURE RELIEF VENT WITH ATMOSPHERIC RELEASE

### Function

The FAV Systems Vapor-Tight Model POTA Pressure Relief Vent with Atmospheric Release is designed for pressure relief in applications that allow the release of tank vapors into the atmosphere.

### Construction

The vent is a one piece body design, which is an extremely rugged weld body unit. Taller guide rods ensure that a full open valve position is obtainable. All vents utilize FAV Systems patented Counter-force Pressure Suspended Pallet and bolt in stainless steel seat and internal components.

### Special Features

FAV Systems patented Counter-force Pressure Suspended Pallet conforms to the seat like no other valve on today's market. The inflating effect of the diaphragm increases as the pressure in the vent rises. This means that when the vent is closer to its set point, the seal is at its greatest performance. Seat leakage for a 1/2 oz/sq" setting is less than 0.5 SCFH for all sizes at 90% of set point. All vents come standard with 316 Stainless Steel internal components which include; guide rod assembly, bolts and nuts, seats, and Counter-force Pressure Suspended Pallet.

### Performance and Quality

We stand by quality and reliability in our products. That is why our vents are set at our factory. With each vent you will receive a certification sheet showing the exact set point of the pressure valve, as well as the leak rate for the valve. This certification sheet is to show our commitment to quality and performance. We don't just claim to be the best, we prove it everyday. Call us for a taste of tomorrow's technology...today.

- \* One piece body construction
- \* Sizes from 2" through 12" A.N.S.I. are STANDARD.
- \* Optional D.I.N., B.S., J.I.S., or National Pipe Thread connections are special order
- \* Available in carbon steel, stainless steel, aluminum and hastelloy
- \* Pressure settings from 0.4 oz/sq"



High pressure valve assembly for pressure settings up to 14.9 PSI - only in 2" to 6" pipe away or to atmosphere



### How To Order

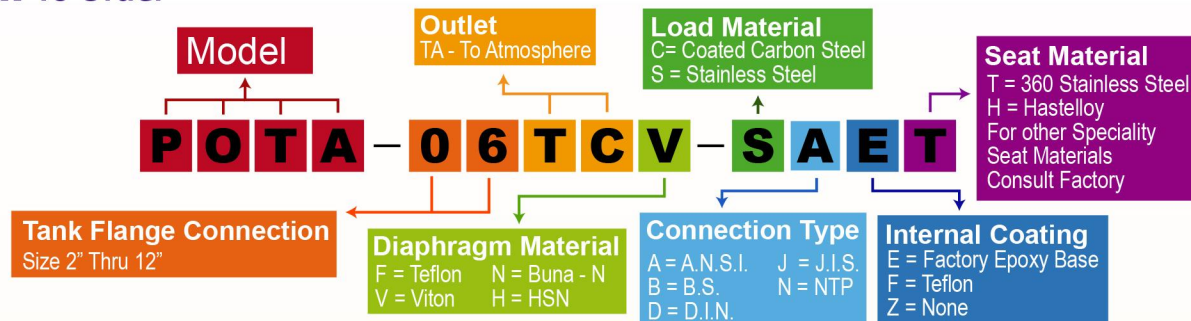

Example: The above order number indicates a Pressure vent with Pipe-away construction. Tank Flange connection is 6", Carbon Steel body, Viton diaphragm, Weight loaded with Steel weight material, and Factory Epoxy Base Internal Coating.

SPECIALIZED IN PREVENTING FUGITIVE EMISSIONS

Contact: 1 (956) 589 8832

www.favsystems.com